

# Ethics and Genetics

## Examining a crossroads in nursing through a case study

Laura Curr Beamer, PhD, DNP, AOCNP®, AOCNS®



**BACKGROUND:** The field of genetics and genomics is rapidly expanding, particularly in oncology. Genetics and genomics can lead to ethical concerns. Oncology nurses must balance the need for evidence-based oncology care with that of ethical care for patients and their family members.

**OBJECTIVES:** The purpose of this article is to provide an overview of cancer genetics and ethics and their impact on oncology nurses, patients, and families.

**METHODS:** A case study of familial adenomatous polyposis (FAP) is offered to illustrate the impact of a hereditary cancer syndrome on several generations of a family and ethical issues surrounding cancer genetics. In addition, a brief review of FAP, gene and tissue biobanking, and genome editing is provided.

**FINDINGS:** Genetics, genomics, and pharmacogenomics are ubiquitous in cancer diagnosis and management. Nurses must be knowledgeable about the ethical issues related to cancer genetics and oncology care to advocate for the needs of patients with cancer. Communication with and education of patients and their families before germline genetic testing may reduce the emergence of ethical dilemmas.

### KEYWORDS

clinical ethics; clinical oncology; gene biobanking; genetics; genome editing

### DIGITAL OBJECT IDENTIFIER

10.1188/17.CJON.730-737

**ONCOLOGY NURSES ARE BUSY PROFESSIONALS**, and knowledge can enable them to deal more effectively with challenges. The purpose of this article is to discuss the ways in which hereditary cancer and ethics affect oncology nurses, patients, and families. Four overarching principles are used to guide ethical healthcare decisions: respect for autonomy, beneficence, nonmaleficence, and distributive justice (Beauchamp & Childress, 2013) (see Figure 1). These principles are important, but the patient, family, and nurse are even more so.

### Case Study

Kevin is a 39-year-old man who experienced intermittent hematochezia for one year. A “carpet of polyps” (i.e., more than 100) was seen on Kevin’s colonoscopy (see Figure 2). Samples were taken of 12 polyps greater than 6 mm in diameter. Pathologic examination revealed 1 polyp with adenocarcinoma and 11 polyps that were benign adenomas. Following consultation with a credentialed genetics professional, genetic testing revealed a deleterious mutation in the *APC* gene found on the long arm of chromosome 5 (i.e., 5q22). Based on genetic testing, Kevin was diagnosed with classic familial adenomatous polyposis (FAP), a hereditary cancer syndrome.

Kevin is married to Sue. Together, they have two children: 10-year-old Andy and 7-year-old Betty. Kevin has a younger brother, 35-year-old Larry, who is married to Maggie. Larry and Maggie are the parents of 9-year-old Janie. Kevin’s father was diagnosed with colorectal cancer (CRC) at age 50 years on routine colonoscopy and died from this disease at age 52 years. Kevin and his father were estranged for many years. Additional details about Kevin’s father’s CRC are not available. The remainder of Kevin’s known family medical history is negative for CRC. Kevin’s family pedigree is provided in Figure 3. Kevin is the proband in this case study. A proband is the individual, or index case, affected by a genetic condition within a family and may be the person presenting for genetic health care (Pagon et al., 2017).

### Familial Adenomatous Polyposis: Risk and Management

Classic FAP is a hereditary condition transmitted via an autosomal dominant pattern of inheritance (Jasperson, Patel, & Ahnen, 2017), which means that the condition can be caused by inheriting only one mutated gene (U.S. National Library of Medicine, 2017a). FAP leads to the development of hundreds to thousands of polyps that eventually become CRC (Jasperson et al., 2017). FAP is also associated with manifestations outside of the colon, including polyps in the stomach and duodenum, desmoid and soft tissue tumors, osteomas, congenital

hypertrophy of the retinal pigment epithelium, and dental anomalies (Jasperson et al., 2017). In addition to CRC, other cancers associated with FAP include medulloblastoma; hepatoblastoma; and papillary thyroid, pancreatic, gastric, and duodenal cancers (National Comprehensive Cancer Network [NCCN], 2017). Kevin, the proband in the case study, did not have any extracolonic manifestations of FAP on his physical examination and diagnostic workup. The average age at benign polyp appearance is age 16 years, whereas the typical age at CRC onset is age 39 years in individuals with FAP (Jasperson et al., 2017). Penetrance refers to the number of people at risk for a disease who actually develop the disease (Lobo, 2008). For example, FAP has a 93% penetrance rate for CRC by age 50 years (Jasperson et al., 2017).

An annual colonoscopy (preferred) or flexible sigmoidoscopy is recommended for individuals at high risk for FAP without known genetic test results, whereas a prophylactic colectomy is recommended for those with a known FAP-associated genetic mutation (Levin et al., 2008; NCCN, 2017). These diagnostic procedures are undertaken to prevent or identify CRC at an early stage to reduce morbidity and mortality (U.S. Department of Health and Human Services Health Resources and Services Administration, 2017).

The ideal age for patients to receive prophylactic surgery is controversial. The youngest reported age at CRC diagnosis in an individual with FAP was age 5 years (Distante et al., 1996). Prophylactic colectomy is a major, life-changing surgery for a child to undergo (Tudyka & Clark, 2012). The decision of when to proceed with surgery depends on psychosocial factors, as well as when the disease burden becomes too great to manage via regularly scheduled surveillance endoscopies (Alkhoury, Franciosi, & Mamula, 2010). Figure 4 shows FAP-associated polyps seen on endoscopy. During surgery, all polyps must be removed to prevent CRC. When the polyps are numerous and distributed

## “Ethical concerns accompany genetics and genomics as a basis for oncology care.”

throughout a large area, removing them via endoscopy becomes almost impossible. When all polyps cannot be removed, a colectomy is needed to prevent CRC.

### Right to Know Versus Right Not to Know

Unlike other types of diagnostic testing, genetic test results may have implications for additional family members (Gallo, Angst, & Knafelz, 2009). Some individuals want to know their genetic status, whereas others prefer not to know. In the case study, Kevin's younger brother, Larry, does not wish to proceed with genetic testing. He wants to live his life without “worrying every day about colon cancer.” However, Larry's wife, Maggie, wants him to have testing for the sake of their daughter, Janie. If Larry tests positive for an APC mutation, Janie should start bowel endoscopy when aged 10–12 years (NCCN, 2017). However, if Larry tests negative for the mutation, Janie could not have inherited the mutation from her father and would not need to start bowel endoscopy during childhood.

### Duty to Know

A patient with cancer can choose not to know the results of his or her genetic test. However, the results of this testing may inform the patient's management options and prognosis. The results may also affect the healthcare needs of close relatives, such as siblings, children, and parents (Gallo et al., 2009).

### Right Not to Know

Larry does not wish to know whether he inherited the APC gene mutation. He has a right to refuse testing. However, Larry's wife, Maggie, could take brother-in-law Kevin's genetic test result to daughter Janie's pediatrician. Maggie and the pediatrician would likely create a plan to start bowel endoscopy and/or test Janie for the known family APC gene mutation within the next few years. If Janie is found to have numerous polyps, develops the manifestations of FAP, or has a positive test result for the APC gene mutation, Larry will be presumed to carry the family APC gene mutation. The manifestations of FAP include hematochezia, abdominal pain, persistent diarrhea, anemia, and fatigue (Croner,

### FIGURE 1. ETHICAL PRINCIPLES TO GUIDE HEALTHCARE DECISIONS

#### RESPECT FOR AUTONOMY

- Self-rule; freedom from the controlling interference of another; requires adequate understanding to make a meaningful choice

#### BENEFICENCE

- Do good. Prevent or remove evil, and promote good.

#### NONMALEFICENCE

- Do no harm. Do not inflict evil or harm.

#### DISTRIBUTIVE JUSTICE

- Each person should receive an equal share according to need, effort, contribution, merit, and free market exchanges.

**Note.** Based on information from Beauchamp & Childress, 2013.

**FIGURE 2.**  
SURGICALLY RESECTED BOWEL WITH POLYPS



**Note.** This surgically resected bowel shows a "carpet of polyps," which is typically seen in familial adenomatous polyposis.  
**Note.** From National Cancer Institute Visuals Online, by Miguel Rodriguez-Bigas, 2015. Retrieved from <https://visualsonline.cancer.gov/details.cfm?imageid=10069>

Brueckl, Reingruber, Hohenberger, & Guenther, 2005). Larry will likely discover the results of Janie’s test and possibly his own status related to FAP, because the pedigree demonstrates his role as the obligate carrier of the APC gene mutation. An obligate carrier is defined as “a person in a family who we know must carry a mutation because there are affected people in the family who could only have received a mutation from that person” (Genetic and Rare Diseases Information Center, n.d., para. 1). Janie’s need to be rescued (i.e., beneficence) may supersede Larry’s right to autonomy in this scenario.

**Duty to Warn or Rescue**

There is a difference between a legal obligation to share genetic information and a moral obligation to share genetic information. Patients with cancer are not legally required to share genetic test results but may have a moral obligation to share them with relatives at increased risk for a given hereditary cancer genetic syndrome. According to Wertz, Fletcher, and Berg (2003), affected individuals “have an ethical duty to inform relatives in the extended family, once they are informed themselves about the condition” (p. 50). In the case study, if Larry has genetic testing, he should share his results with daughter Janie’s healthcare providers (according to the duty to warn).

Healthcare providers may have a duty to warn or rescue at-risk relatives. The results of several studies identify a pattern of behavior among some individuals with genetic conditions. The individuals indicated a plan to share their genetic results with at-risk relatives but did not follow through on this intention, leaving the relatives uninformed of their risk (Dheensa, Fenwick, &

Lucassen, 2017). Healthcare providers surveyed about their responsibility to patients’ relatives regarding genetic information reported perceiving a duty to the at-risk relatives—but also respect for patients’ privacy (Dheensa, Fenwick, Shkedi-Rafid, Crawford, & Lucassen, 2016).

The ethical position of mutuality requires the health professional to warn at-risk relatives in cases where the patient refuses to share genetic information (Knoppers, 2002). However, four conditions must be met to evoke mutuality, as classically described: (a) The condition must be serious; (b) the at-risk individual must be likely to have the condition; (c) a biological relative of the patient with the established genetic information must be able to be identified; and (d) preventive measures or treatments must be available (Knoppers, 2002; Wertz et al., 2003). There is a legal precedent to hold providers accountable for duty to warn in a case of FAP. In the case of *Safer v. Estate of Pack* (1996), the estate of physician George Pack was sued by Donna Safer, the daughter of one of Pack’s former patients. Safer’s father, Robert Batkin, died of a colon blockage and had multiple polyps (Schleiter, 2009). Safer contended that Pack did not warn Batkin’s family of his hereditary condition, and Safer later developed a colon blockage

**FIGURE 3.**  
CASE STUDY: PEDIGREE FOR KEVIN'S FAMILY

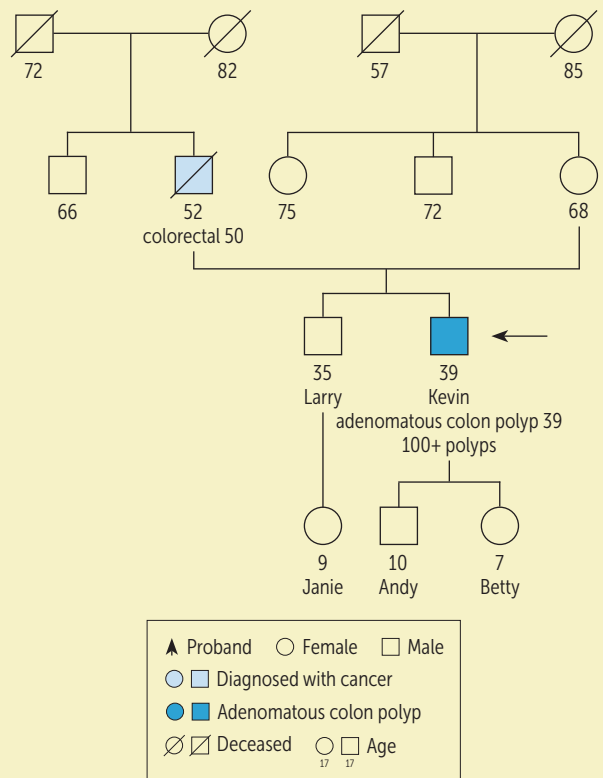

Downloaded on 07-22-2024. Single-user license only. Copyright 2024 by the Oncology Nursing Society. For permission to post online, reprint, adapt, or reuse, please email pubpermissions@ons.org. ONS reserves all rights.

and multiple polyps as well (Schleiter, 2009). She successfully sued Pack's estate for a breach in duty to warn (Schleiter, 2009).

Family dynamics also play a role in family communication of genetic information. For example, in the case study, Kevin's father died from CRC at a young age. Whether Kevin's father had FAP is unknown; however, the father's having this condition is likely, given his young age at diagnosis and Kevin's FAP diagnosis. If the father had shared his health history with his sons, Kevin may have avoided developing CRC by having a prophylactic colectomy when his risk for FAP was established and confirmed.

Genetics healthcare providers can help to bridge the gap in communication among estranged relatives. They can assist the proband in writing a letter to family members about genetic test results, physical examination findings, and recommendations for how to seek genetic care. The letter may identify the patient or be more indirect with this information, as in the following example:

A relative who prefers to remain anonymous was found to have a mutation (change) in the *APC* gene associated with a genetic condition called familial adenomatous polyposis (FAP). FAP leads to polyp (i.e., clump of cells on the lining of the large intestine) formation and risk for colon cancer. There are options to reduce cancer risk. You should speak with a genetics healthcare provider about your risk for this condition and ways to manage this risk. Jane Smith is a nurse practitioner at a facility near you who specializes in genetic conditions. She has an office in your town, and her phone number is 999-999-9999.

### Testing Children for Hereditary Cancer Genetic Conditions

The decision to test a child for a hereditary cancer genetic condition depends on the age of expected onset (i.e., childhood or adulthood) and whether preventive measures are known. For example, the clinical manifestations of FAP begin in childhood. In the presence of an *APC* gene mutation, bowel endoscopy may start when an individual is aged 10–12 years (Levin et al., 2008; NCCN, 2017) or at puberty (Syngal et al., 2015). This screening can help to save the child's life. If the child tests negative for a known family mutation in the *APC* gene, the child can be spared unnecessary endoscopic screenings (Hyer & Fell, 2001; Levine et al., 2010).

Predictive genetic testing is used to identify mutations that increase the risk for developing conditions such as hereditary cancers among asymptomatic individuals (U.S. National Library of Medicine, 2017c). According to the American Academy of Pediatrics Committee on Bioethics, Committee on Genetics, and American College of Medical Genetics and Genomics Social, Ethical, and Legal Issues Committee (2013), "predictive genetic testing for adult-onset conditions generally should be deferred [until adulthood] unless an intervention initiated in childhood

**FIGURE 4.**  
BOWEL ENDOSCOPY WITH POLYPS



**Note.** This bowel endoscopy shows polyps that are typically seen in familial adenomatous polyposis.

**Note.** From National Cancer Institute Visuals Online, by Miguel Rodriguez-Bigas, 2015. Retrieved from <https://visualsonline.cancer.gov/details.cfm?imageid=10067>

may reduce morbidity or mortality" (p. 621). The American College of Medical Genetics (Ross, Saal, David, & Anderson, 2013), National Society of Genetic Counselors (2017), and Human Genetics Society of Australasia (2014) have guidelines or position statements that complement the policy statement set forth by the American Academy of Pediatrics Committee on Bioethics, Committee on Genetics, and American College of Medical Genetics and Genomics Social, Ethical, and Legal Issues Committee. *BRCA1* and *BRCA2* are examples of genetic mutations that could be but should not be tested for in childhood because no measures are currently used in childhood to prevent or screen for cancers associated with these mutations. Conversely, genetic testing of children for conditions with adult onset may be indicated if preventive measures exist that may reduce the risk of developing a genetic condition as an adult. Even so, the benefits of genetic testing (e.g., saving a life, reducing morbidity) must outweigh the risks (e.g., emotional, social, and financial sequelae) (U.S. National Library of Medicine, 2017b).

### Pharmacogenomics and Chemoprevention in Familial Adenomatous Polyposis

Oncology nurses must become familiar with pharmacogenomics, which "is the study of how genes affect a person's response to drugs," to provide safe, therapeutic patient care (U.S. National Library of Medicine, 2017d, para. 1). Medications such as celecoxib (Celebrex®) are used to reduce the recurrence of colon polyps following polypectomy among individuals



with FAP (NCCN, 2017). Some individuals have variations in their *CYP2C9* genes that lead to poor metabolism of celecoxib and toxicity (PharmGKB, n.d.). These individuals require a lower dose of celecoxib (PharmGKB, n.d.). Genetic testing for variations in the *CYP2C9* gene exists (National Center for Biotechnology Information, n.d.).

### Genetic Biobanks and Genetic Data

To provide better, more effective precision oncology care, it is important that patients with cancer participate in clinical trials and that researchers pool their data and share results. However, more infrastructure is needed to accomplish this goal (Bertier, Carrot-Zhang, Ragoussis, & Joly, 2016). Genetic biobanks are used to store blood and/or tissue specimens that may answer future research questions, and tissue biobanking is supported by recommendations and financial support from the National Cancer Advisory Board and its Blue Ribbon Panel on the National Cancer Moonshot Initiative. Blood or tissue donation and the health history of individuals affected or unaffected by cancer are needed, but care must be taken to protect the confidentiality of the donor (Siminoff et al., 2017). Specimens may be deidentified during the research process. Deidentification may cause an issue if researchers discover a finding that may help the donor and/or the donor's family. The patient consent, written in lay terms, often stipulates a process that allows for patients and family members to contact the research team or for the research team to recontact patients and family members (Holm, 2017).

#### FIGURE 5. RESOURCES FOR PATIENTS AND FAMILIES

##### REFERRAL TO CANCER GENETICS SERVICES

##### NATIONAL CANCER INSTITUTE CANCER GENETICS SERVICES DIRECTORY

- [www.cancer.gov/about-cancer/causes-prevention/genetics/directory](http://www.cancer.gov/about-cancer/causes-prevention/genetics/directory)

##### NATIONAL SOCIETY OF GENETIC COUNSELORS

- [www.nsgc.org](http://www.nsgc.org)

##### REFERRAL TO QUALITY, APPROPRIATE INFORMATION (DEVELOPMENT, CULTURE, LITERACY)

##### GENETICS HOME REFERENCE

- <https://ghr.nlm.nih.gov>

##### NATIONAL CANCER INSTITUTE—ABOUT CANCER

- [www.cancer.gov/about-cancer](http://www.cancer.gov/about-cancer)

##### NATIONAL INSTITUTES OF HEALTH—PARTICIPATE IN CLINICAL STUDIES

- <https://clinicalcenter.nih.gov/participate1.html>

##### PARTICIPATION IN HEALTH RESEARCH STUDIES

- <https://guides.library.harvard.edu/healthresearch>

Predicting the findings of future studies using genetic biobank specimens is difficult because technologies are always emerging. In addition, incidental findings are a concern in any genetic study. Incidental findings, also known as secondary findings, may affect the health of participants, are found by accident, and are not included in the aims of the study (Roche & Berg, 2015; Virani & Longstaff, 2015). These incidental or secondary findings include mutations that increase an individual's risk for genetic conditions with established management (e.g., FAP, hereditary breast and ovarian cancer) and mutations that healthcare providers are much less knowledgeable about (Green et al., 2013).

### Informed Consent

Appelbaum et al. (2014) have proposed four models of informed consent for return of incidental findings in genetic research. In the first model, informed consent is collected during study enrollment and provides extensive information up front. This information includes the nature, categories, and likelihood of incidental findings; options to receive any or all the findings; benefits and risks related to return of incidental findings; implications for relatives; data confidentiality; and data management if the participant becomes disabled or dies. This model of consent maximizes the participant's autonomy.

In Appelbaum et al.'s (2014) second model, informed consent is collected in stages. Incidental findings are briefly mentioned during the consent process. When and if incidental findings are discovered, more detailed informed consent is obtained. The model allows for participant decision making based on life changes occurring after initial consent was provided.

Appelbaum et al.'s (2014) third model involves informed consent mandating the return of specific categories of incidental findings at the time of discovery. This model may interfere with the participant's autonomy because the participant is not free to select which incidental findings are disclosed.

In the fourth model, participants are referred to third parties for consent and return of incidental findings (Appelbaum et al., 2014). Concerns about this model include quality of the information provided by the third party and costs that may not be covered by the genetic study.

### Gene Banks

Several types of gene banking exist. For example, storing cord blood stem cells is possible. The National Institute of General Medical Sciences (2017) maintains the Human Genetic Cell Repository, which is housed at the Coriell Institute for Medical Research (n.d.) and contains 41 collections, including apparently healthy cells (i.e., no known diseases) and heritable disease cells (e.g., *BRCA1*, *BRCA2*, Gardner syndrome [subtype of FAP]). Gene banking may also be used for terminally ill patients (Quillen, Bodurtha, Siminoff, & Smith, 2011). Oncology-related reasons to consider gene banking include a lack of positive genetic test results in the presence of cancer diagnosed at an earlier than typical

age and/or multiple primary cancers in the dying patient (Quillen, Bodurtha, & Smith, 2015). The genetic specimen is saved in the hope that a future test will provide answers to benefit the family (Quillen et al., 2015).

## Genome Editing

### The Science

Gene and genome editing is another focus of ethical concern, where discussion about policy and guidelines continues. A genome is the complete set of genes (i.e., all the DNA) in an individual (U.S. National Library of Medicine, 2017d), whereas the word *genetic* means “relating to genes or heredity” (Genetic, 2017). Genome editing is the process of precisely removing an undesirable sequence of DNA, often using an enzyme (e.g., Cas9 endonuclease) and a guiding RNA, and replacing it with a more desirable sequence of DNA (Genome Editing Core, n.d.; Porteus, 2015). This technique is known as CRISPR (clustered regularly interspaced short palindromic repeats) (Wright, Nuñez, & Doudna, 2016). A palindrome is a genetic sequence that reads the same from front to back or from back to front. Additional methods used to edit genomes include zinc finger nucleases and transcription activator-like effector nucleases (Reardon, 2016). A brief informative video on gene editing, produced by the Royal Society, is available at [www.youtube.com/watch?v=XPDb8tqgfjY](http://www.youtube.com/watch?v=XPDb8tqgfjY).

### FIGURE 6. PROFESSIONAL RESOURCES FOR NURSES

#### GENETIC SYNDROMES

##### GENEREVIEWS®

- [www.ncbi.nlm.nih.gov/books/NBK1116](http://www.ncbi.nlm.nih.gov/books/NBK1116)

##### NATIONAL HUMAN GENOME RESEARCH INSTITUTE

- [www.genome.gov/issues](http://www.genome.gov/issues)

#### HEALTHCARE ETHICS

##### AMERICAN NURSES ASSOCIATION—CODE OF ETHICS FOR NURSES WITH INTERPRETIVE STATEMENTS

- <http://bit.ly/2hQzLZL>

##### AMERICAN NURSES ASSOCIATION AND INTERNATIONAL SOCIETY OF NURSES IN GENETICS—GENETICS/GENOMICS NURSING: SCOPE AND STANDARDS OF PRACTICE (2ND ED.)

- [www.nursesbooks.org/GeneticsGenomicsNursing-SecondEdition](http://www.nursesbooks.org/GeneticsGenomicsNursing-SecondEdition)

#### RESEARCH ETHICS

##### NATIONAL INSTITUTES OF HEALTH CLINICAL CENTER DEPARTMENT OF BIOETHICS

- [www.bioethics.nih.gov/home/index.shtml](http://www.bioethics.nih.gov/home/index.shtml)
- [https://bioethics.nih.gov/education/FNIH\\_BioethicsBrochure\\_WEB.PDF](https://bioethics.nih.gov/education/FNIH_BioethicsBrochure_WEB.PDF)

### IMPLICATIONS FOR PRACTICE

- Use knowledge of ethical issues and principles related to cancer genetics and oncology care to advocate for the needs of patients with cancer and their families.
- Note that most healthcare systems have a process in place for patients to request a complimentary ethics consultation when concerns arise.
- Know that resources are readily available to help oncology nurses locate qualified and credentialed cancer genetics healthcare providers for further discussion and clarification when ethical issues appear.

### Ethical Aspects

Some scientists argue against genome editing. For example, Marcy Darnovsky (2016), executive director of the Center for Genetics and Society, stated, “By all accounts, far too much is unknown about issues including off-target mutations (unintentional edits to the genome), persistent editing effects, genetic mechanisms in embryonic and fetal development, and longer-term health and safety consequences” (para 6). The National Institutes of Health refuses to consider grant applications for research that involves specific attempts to edit genes in human germ cells (sperm, ova) to intentionally change the genes passed down to the offspring of that individual (Collins, 2016). Darnovsky (2016) and Collins (2016) are speaking against gene editing in human germ cells and embryos (e.g., to create perfect designer babies), not in cancer and other health conditions diagnosed later in life (i.e., after birth).

However, arguments supporting genome editing exist. John Harris (2016), a professor emeritus in science ethics at the University of Manchester, in contrast to Darnovsky’s (2016) point, argues in favor of allowing gene editing of human embryos, positing that embryo modification is no more unnatural than current treatment of disease because diseases are “natural.”

At least one group supports a middle ground approach to genome editing. The Hinxton Group is an international consortium of scientists, policymakers, journal editors, and the public that focuses on stem cell research. They propose a level of permissibility on a continuum for genome editing. Gene editing performed as an enhancement (e.g., baby’s eye color) would be less permissible than gene editing for mutations that cause serious disease (e.g., cancer, Huntington disease) (Hinxton Group, 2015).

### Conclusion

Nurses are encouraged to consult with the ethics department or professionals in their institution when ethical concerns arise. Information on referring patients to cancer genetic services, as well as patient- and family-friendly resources about cancer, ethics, research, and genetics, is provided in Figure 5. Figure 6 offers quality professional resources on genetics, research ethics, and healthcare ethics.

Genetics, genomics, and pharmacogenomics have emerged as a foundation for cancer diagnosis and treatment. When taking care of patients and family members, clinicians rely on a sound understanding of ethical issues associated with genetics and

cancer care. Thorough and comprehensive communication and education of patients and their families before genetic testing may reduce the anxiety associated with ethical questions.

Ethical concerns accompany genetics and genomics as a basis for oncology care. The case study presented in this article exposed ethical concerns, including duty to know and right not to know genetic status, duty to warn or rescue relatives, and genetic testing of children.

**Laura Curr Beamer, PhD, DNP, AOCNP®, AOCNS®**, is an assistant professor in the School of Nursing at Northern Illinois University in DeKalb. Beamer can be reached at [labeamer@gmail.com](mailto:labeamer@gmail.com), with copy to [CJONEditor@ons.org](mailto:CJONEditor@ons.org). (Submitted July 2017. Accepted August 30, 2017.)

The author takes full responsibility for this content and did not receive honoraria or disclose any relevant financial relationships. The article has been reviewed by independent peer reviewers to ensure that it is objective and free from bias. Mention of specific products and opinions related to those products do not indicate or imply endorsement by the Oncology Nursing Society.

## REFERENCES

- Alkhoury, N., Franciosi, J.P., & Mamula, P. (2010). Familial adenomatous polyposis in children and adolescents. *Journal of Pediatric Gastroenterology and Nutrition*, *51*, 727–732. <https://doi.org/10.1097/MPG.0b013e3181e1a224>
- American Academy of Pediatrics Committee on Bioethics, Committee on Genetics, & American College of Medical Genetics and Genomics Social, Ethical, and Legal Issues Committee. (2013). Ethical and policy issues in genetic testing and screening of children. *Pediatrics*, *131*, 620–622. <https://doi.org/10.1542/peds.2012-3680>
- Appelbaum, P.S., Parens, E., Waldman, C.R., Klitzman, R., Fyer, A., Martinez, J., . . . Chung, W.K. (2014). Models of consent to return of incidental findings in genomic research. *Hastings Center Report*, *44*, 22–32. <https://doi.org/10.1002/hast.328>
- Beauchamp, T.L., & Childress, J.F. (2013). *Principles of biomedical ethics* (7th ed.). New York, NY: Oxford University Press.
- Bertier, G., Carrot-Zhang, J., Ragoussis, V., & Joly, Y. (2016). Integrating precision cancer medicine into healthcare—Policy, practice, and research challenges. *Genome Medicine*, *8*, 108. <https://doi.org/10.1186/s13073-016-0362-4>
- Collins, F. (2016). *Thoughts on gene editing*. Retrieved from [http://nationalacademies.org/cs/groups/genesite/documents/webpage/gene\\_173636.pdf](http://nationalacademies.org/cs/groups/genesite/documents/webpage/gene_173636.pdf)
- Coriell Institute for Medical Research. (n.d.). Heritable diseases and normal variants. Retrieved from <https://catalog.coriell.org/1/NIGMS/Collections/Heritable-Diseases>
- Croner, R.S., Brueckl, W.M., Reingruber, B., Hohenberger, W., & Guenther, K. (2005). Age and manifestation related symptoms in familial adenomatous polyposis. *BMC Cancer*, *5*, 24. <https://doi.org/10.1186/1471-2407-5-24>
- Darnovsky, M. (2016). Con: Do not open the door to editing genes in future humans. *National Geographic*. Retrieved from <http://www.nationalgeographic.com/magazine/2016/08/human-gene-editing-pro-con-opinions>
- Dheensa, S., Fenwick, A., & Lucassen, A. (2017). Approaching confidentiality at a familial level in genomic medicine: A focus group study with healthcare professionals. *BMJ Open*, *7*, e012443. <https://doi.org/10.1136/bmjopen-2016-012443>
- Dheensa, S., Fenwick, A., Shkedi-Rafid, S., Crawford, G., & Lucassen, A. (2016). Health-care professionals' responsibility to patients' relatives in genetic medicine: A systematic review and synthesis of empirical research. *Genetics in Medicine*, *18*, 290–301. <https://doi.org/10.1038/gim.2015.72>
- Distante, S., Nasioulas, S., Somers, G.R., Cameron, D.J., Young, M.A., Forrest, S.M., & Gardner, R.J. (1996). Familial adenomatous polyposis in a 5 year old child: A clinical, pathological, and molecular genetic study. *Journal of Medical Genetics*, *33*, 157–160.
- Gallo, A.M., Angst, D.B., & Knafel, K.A. (2009). Disclosure of genetic information within families. *American Journal of Nursing*, *109*, 65–69. <https://doi.org/10.1097/01.NAJ.0000348607.31983.6e>
- Genetic. (2017). In *English Oxford Living Dictionaries*. Retrieved from <https://en.oxforddictionaries.com/definition/genetic>
- Genetic and Rare Diseases Information Center. (n.d.). Obligate carrier. Retrieved from <https://rarediseases.info.nih.gov/GlossaryDescription/337/0>
- Genome Editing Core. (n.d.). The basics of CRISPR/Cas9. Retrieved from <https://sites.google.com/site/genomeedits/basics>
- Green, R.C., Berg, J.S., Grody, W.W., Kalia, S.S., Korf, B.R., Martin, C.L., . . . Biesecker, L.G. (2013). ACMG recommendations for reporting of incidental findings in clinical exome and genome sequencing. *Genetics in Medicine*, *15*, 565–574. <https://doi.org/10.1038/gim.2013.73>
- Harris, J. (2016). Pro: Research on gene editing in humans must continue. *National Geographic*. Retrieved from <http://www.nationalgeographic.com/magazine/2016/08/human-gene-editing-pro-con-opinions>
- Hinxton Group. (2015). *Statement on genome editing technologies and human germline genetic modification*. Retrieved from [http://www.hinxtongroup.org/hinxton2015\\_statement.pdf](http://www.hinxtongroup.org/hinxton2015_statement.pdf)
- Holm, I.A. (2017). Pediatric issues in return of results and incidental findings: Weighing autonomy and best interests. *Genetic Testing and Molecular Biomarkers*, *21*, 155–158.
- Human Genetics Society of Australasia. (2014). *Pre-symptomatic and predictive testing for children and young adults*. Retrieved from <https://www.hgsa.org.au/documents/item/272>
- Hyer, W., & Fell, J.M. (2001). Screening for familial adenomatous polyposis. *Archives of Disease in Childhood*, *84*, 377–380. <http://doi.org/10.1136/adc.84.5.377>
- Jasperson, K.W., Patel, S.G., & Ahnen, D.J. (2017). APC-associated polyposis conditions. In R.A. Pagon, M.P. Adam, H.H. Ardinger, S.E. Wallace, A. Amemiya, L.J. Bean, . . . K. Stephens (Eds.), *GeneReviews®*. Seattle, WA: University of Washington. Retrieved from <https://www.ncbi.nlm.nih.gov/books/NBK1345>
- Knoppers, B.M. (2002). Genetic information and the family: Are we our brother's keeper? *Trends in Biotechnology*, *20*, 85–86.
- Levin, B., Lieberman, D.A., McFarland, B., Smith, R.A., Brooks, D., Andrews, K.S., . . . Winawer, S.J. (2008). Screening and surveillance for the early detection of colorectal cancer and adenomatous polyps, 2008: A joint guideline from the American Cancer Society, the US Multi-Society Task Force on Colorectal Cancer, and the American College of Radiology. *CA: A Cancer Journal for Clinicians*, *58*, 130–160. <https://doi.org/10.3322/CA.2007.0018>
- Levine, F.R., Coxworth, J.E., Stevenson, D.A., Tuohy, T., Burt, R.W., & Kinney, A.Y. (2010). Parental attitudes, beliefs, and perceptions about genetic testing for FAP and colorectal cancer surveillance in minors. *Journal of Genetic Counseling*, *19*, 269–279. <https://doi.org/10.1007/s10897-010-9285-1>
- Lobo, I. (2008). Same genetic mutation, different genetic disease phenotype. *Nature Education*, *1*, 64.
- National Center for Biotechnology Information. (n.d.). 1559[gened]. *GTR: Genetic Testing Registry*. Retrieved from <https://www.ncbi.nlm.nih.gov/gtr/all/tests/?term=1559%5Bgened%5D>
- National Comprehensive Cancer Network. (2017). *NCCN Clinical Practice Guidelines in Oncology (NCCN Guidelines®): Genetic/familial high-risk assessment: Colorectal [v.3.2017]*. Retrieved from [https://www.nccn.org/professionals/physician\\_gls/pdf/genetics\\_colon.pdf](https://www.nccn.org/professionals/physician_gls/pdf/genetics_colon.pdf)

- National Institute of General Medical Sciences. (2017). NIGMS Human Genetic Cell Repository. Retrieved from <https://www.nigms.nih.gov/Research/specificareas/hgcr/Pages/default.aspx>
- National Society of Genetic Counselors. (2017). Genetic testing of minors for adult-onset conditions. Retrieved from <http://www.nsgc.org/p/bl/et/blogid=475blogaid=860>
- Pagon, R.A., Adam, M.P., Ardinger, H.H., Wallace, S.E., Amemiya, A., Bean, L.J. . . . Stephens, K. (Eds.). (2017). *GeneReviews* glossary. *GeneReviews*®. Seattle, WA: University of Washington. Retrieved from <https://www.ncbi.nlm.nih.gov/books/NBK5191>
- PharmGKB. (n.d.). Celecoxib. Retrieved from <https://www.pharmgkb.org/chemical/PA448871#tabview=tab0&subtab=32>
- Porteus, M.H. (2015). Towards a new era in medicine: Therapeutic genome editing. *Genome Biology*, 16, 286. <https://doi.org/10.1186/s13059-015-0859-y>
- Quillin, J.M., Bodurtha, J.N., Siminoff, L.A., & Smith, T.J. (2011). Physicians' current practices and opportunities for DNA banking of dying patients with cancer. *Journal of Oncology Practice*, 7, 183–187. <https://doi.org/10.1200/JOP.2010.000190>
- Quillin, J.M., Bodurtha, J.N., & Smith, T.J. (2015). Fast facts and concepts #206: Genetic screening and DNA banking at the end of life. *Palliative Care Network of Wisconsin*. Retrieved from <https://www.mypcnw.org/blank-d520x>
- Reardon, S. (2016, June 22). First CRISPR clinical trial gets green light from US panel. *Nature*. <https://doi.org/10.1038/nature.2016.20137>
- Roche, M.I., & Berg, J.S. (2015). Incidental findings with genomic testing: Implications for genetic counseling practice. *Current Genetic Medicine Reports*, 3, 166–176.
- Ross, L.F., Saal, H.M., David, K.L., & Anderson, R.R. (2013). Technical report: Ethical and policy issues in genetic testing and screening of children. *Genetics in Medicine*, 15, 234–245. <https://doi.org/10.1038/gim.2012.176>
- Safer v. Estate of Pack, 146 N.J. 568, 683 A.2d 1160 (1996)
- Schleier, K.E. (2009). A physician's duty to warn third parties of hereditary risk. *Virtual Mentor*, 11, 697–700.
- Siminoff, L.A., Wilson-Genderson, M., Mosavel, M., Barker, L., Trgina, J., & Traino, H.M. (2017). Confidentiality in biobanking research: A comparison of donor and nondonor families' understanding of risks. *Genetic Testing and Molecular Biomarkers*, 21, 171–177.
- Syngal, S., Brand, R.E., Church, J.M., Giardiello, F.M., Hampel, H.L., & Burt, R.W. (2015). ACG clinical guideline: Genetic testing and management of hereditary gastrointestinal cancer syndromes. *American Journal of Gastroenterology*, 110, 223–262.
- Tudyka, V.N., & Clark, S.K. (2012). Surgical treatment in familial adenomatous polyposis. *Annals of Gastroenterology*, 25, 201–206.
- U.S. Department of Health and Human Services Health Resources and Services Administration. (2017). *Colorectal cancer screening*. Retrieved from <https://www.hrsa.gov/sites/default/files/quality/toolbox/508pdfs/colorectalcancerscreening.pdf>
- U.S. National Library of Medicine. (2017a). What are the different ways in which a genetic condition can be inherited? Retrieved from <https://ghr.nlm.nih.gov/primer/inheritance/inheritancepatterns>
- U.S. National Library of Medicine. (2017b). What are the risks and limitations of genetic testing? Retrieved from <https://ghr.nlm.nih.gov/primer/testing/riskslimitations>
- U.S. National Library of Medicine. (2017c). What are the types of genetic tests? Retrieved from <https://ghr.nlm.nih.gov/primer/testing/uses>
- U.S. National Library of Medicine. (2017d). What is a genome? Retrieved from <https://ghr.nlm.nih.gov/primer/hgp/genome>
- Virani, A.H., & Longstaff, H. (2015). Ethical considerations in biobanks: How a public health ethics perspective sheds new light on old controversies. *Journal of Genetic Counseling*, 24, 428–432. <https://doi.org/10.1007/s10897-014-9781-9>
- Wertz, D.C., Fletcher, J.C., & Berg, K. (2003). *Review of ethical issues in medical genetics: Report of consultants to WHO*. Retrieved from [http://www.who.int/genomics/publications/en/ethical\\_issues\\_in\\_medgenetics%20report.pdf](http://www.who.int/genomics/publications/en/ethical_issues_in_medgenetics%20report.pdf)
- Wright, A.V., Nuñez, J.K., & Doudna, J.A. (2016). Biology and applications of CRISPR systems: Harnessing nature's toolbox for genome engineering. *Cell*, 164, 29–44.

### CNE ACTIVITY

#### EARN 0.5 CONTACT HOURS



ONS members can earn free CNE for reading this article and completing an evaluation online. To do so, visit [cjon.ons.org/cne](http://cjon.ons.org/cne) to link to this article and then access its evaluation link after logging in.

Certified nurses can earn 0.5 ILNA points for one of the following based on reading the article and completing an evaluation online:

- 0.5 ILNA Scientific Basis/Diagnosis OR Professional points toward OCN®, AOCNP®, AOCNS®, CPHON®, or CBCN®
- 0.5 ILNA Basic Concepts OR Professional points toward BMTCN®

### QUESTIONS FOR DISCUSSION

#### USE THIS ARTICLE FOR JOURNAL CLUB



Journal club programs can help to increase your ability to evaluate the literature and translate those research findings to clinical practice, education, administration, and research. Use the following questions to start the discussion at your next journal club meeting.

- In your practice, do you advocate for your patients and family members about ethical issues related to cancer genetics and oncology care? What are those issues?
- When educating your patients, how do you start a discussion about ethical issues related to cancer genetics (e.g., duty to know and right not to know genetic status, duty to warn or rescue relatives, genetic testing of children)?
- How would you start a conversation with one of your patients who has not disclosed genetics results to at-risk relatives? What are ethical issues associated with disclosing or not disclosing?

Visit <http://bit.ly/1vUqbVj> for details on creating and participating in a journal club. Photocopying of this article for discussion purposes is permitted.